



CSI
Model 465

HOUSE-TUG



Made in U.S.A.

**Powder coated Yellow is standard
Optional colors available at extra charge*

The CSI House-Tug has a rugged design specifically for installing manufactured buildings. We use a state-of-the-art track system to allow maneuvering in tight places, soggy soils, and rough terrains. Pulling heavy loads created by modern manufactured homes is no problem for the fully hydrostatic drive and the diesel powered engine. The House-Tug will move the heaviest units into place with ease!



Cutting Systems, Inc.

(877) 844-1274

www.cuttingsys.com

465

ENGINE	Kubota, V2403 TI, 65hp
RADIO REMOTE	Proportional Radio Control
TRACKS	18" Street Pads
TORQUE HUBS	Auburn Power Wheel
TRAVEL SPEED	High: 2.2 mph Low: 1.1 mph
FUEL TANK	30 US Gallons
HYDRAULIC TANK	30 US Gallons
HYDRAULIC WINCH	12,000 lbs. (standard)
HITCH LIFT CAPACITY	27,000 lbs.
AUX. HYDRAULICS	12 GPM @ 3,000 PSI



The maneuverability and easy control of the House-Tug will amaze you. It can actually turn around in its own length, and crawl steep inclines to get into and out of places you would never take other machines. The House-Tug's user-friendly radio remote gives you full control of the little giant. The state-of-the-art industrial control system is extremely rugged and able to provide many years of dependable service.

Weight: w/Blade 10,400 lbs.
no Blade 9,900 lbs.

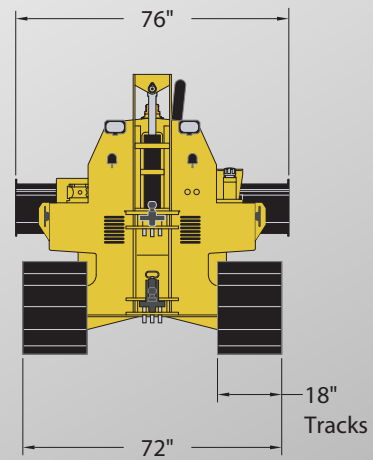
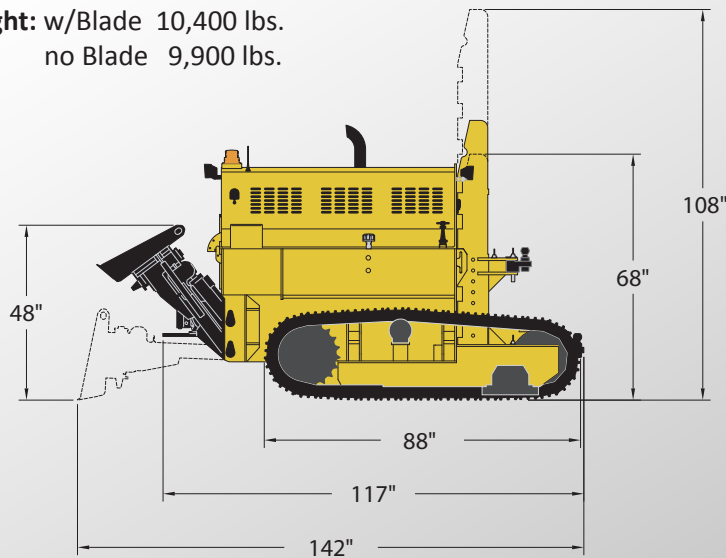

Cutting Systems, Inc.

774 Zeb Road
Union Grove, NC

email@cuttingsys.com

Cutting Systems, Inc. reserves the right to change specifications and to add improvements to our products at any time without notice or obligation.

2021-05