

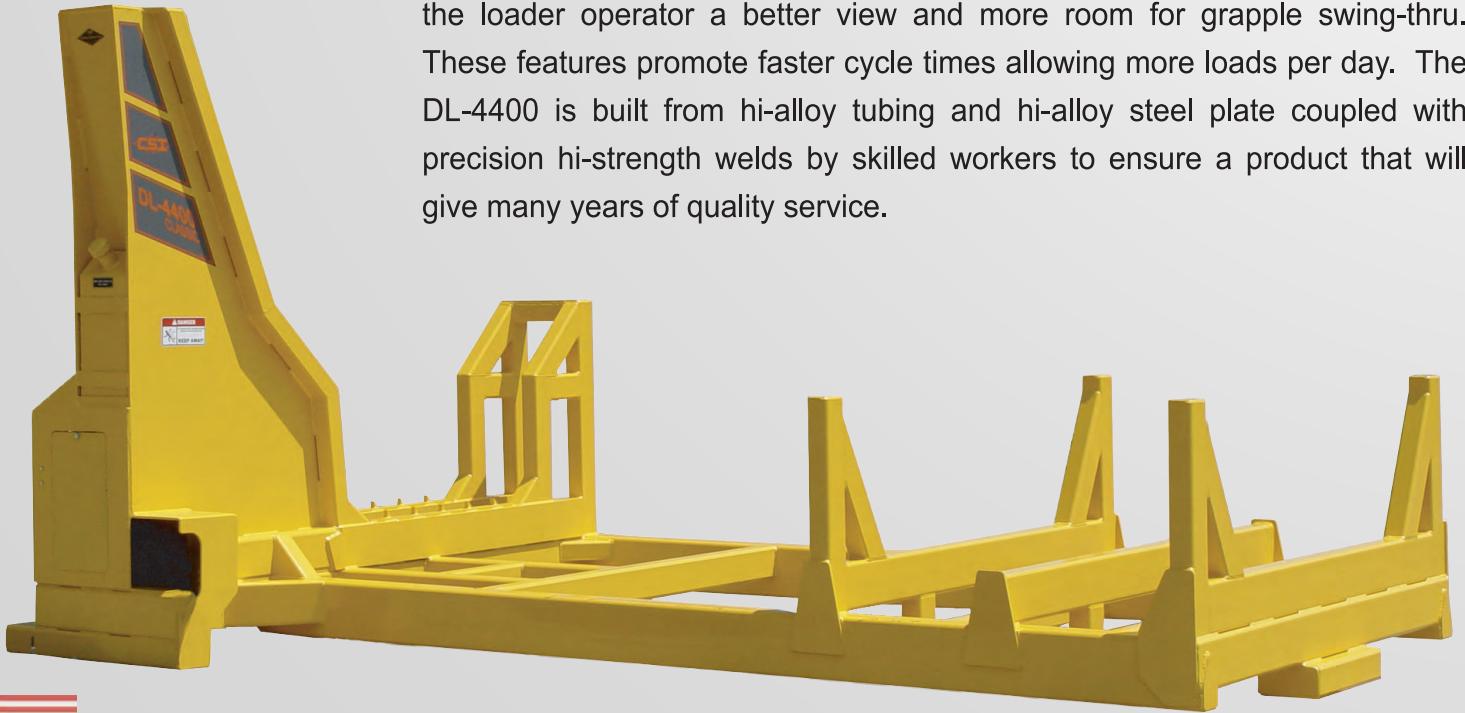

# Model DL-4400

## SLASHER SAW

The CSI Model DL-4400 Slasher features a unique style saw box that allows the loader operator a better view and more room for grapple swing-thru. These features promote faster cycle times allowing more loads per day. The DL-4400 is built from hi-alloy tubing and hi-alloy steel plate coupled with precision hi-strength welds by skilled workers to ensure a product that will give many years of quality service.



Made in U.S.A.

*\* shown with Standard 12ft Chassis*



Cutting Systems, Inc.

Call Toll-Free: 1-877-844-1274

[email@cuttingsys.com](mailto:email@cuttingsys.com)

## Basic Chassis Configurations

### Standard 12ft Chassis

for Reversible box

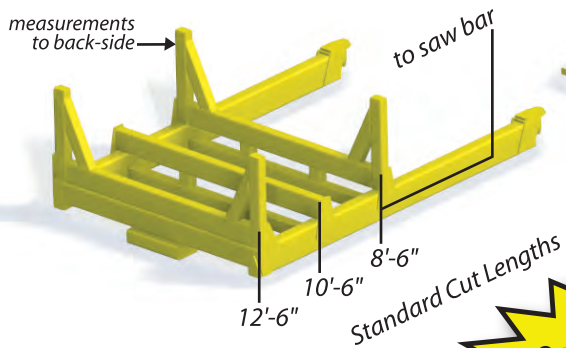

### Extended 18ft Chassis

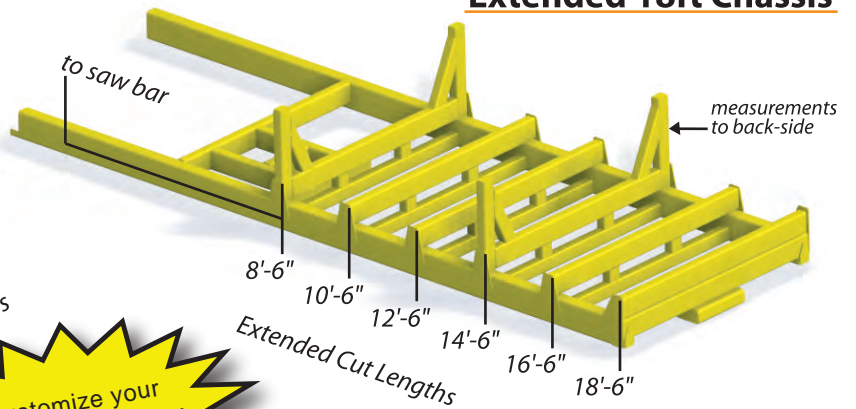

Customize your chassis to suit your individual needs!!

## Features

- Direct Drive Saw Chain
- Four 3/4" Bar Mount Bolts
- Cam-type Chain Adjustment
- Auto Adjusting Feed System
- Hydraulic Cushion Bar Stop

## Saw Buck Options



V-buck

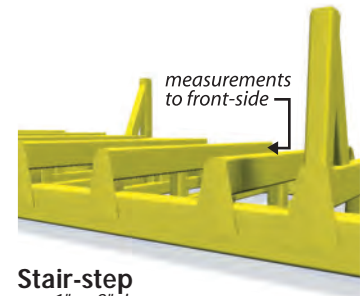

Stair-step  
1" or 2" rises



Easily swap sides of the chassis for added versatility!

## Specifications

Frame Construction	Alloy steel
Maximum Opening	44 inches
Saw Bar	59" roller tip
Saw Chain	3/4 pitch with 96 drive links
Drive Sprocket	7" case hardened, 14 pin
Hydraulics	50 - 75 GPM @ 2,000 - 2,500 PSI
Chain Oiler	Automatic piston actuated
Chain Oil Reservoir	3.7 gallons
Height	88 inches
Width	98 inches
Weight	(as shown on front) 4,000 lbs.

\*Measures from eyelet to eyelet on Reversible box only.



Cutting Systems, Inc.  
774 Zeb Road  
Union Grove, NC 28689

www.cuttingsys.com

Cutting Systems, Inc. reserves the right to change specifications and to add improvements to our products at any time without notice or obligation.

2013-07

